

EN Caution: Always use appropriate fixings to suit your type of wall. / **ES ¡Atención!** Use siempre las fijaciones apropiadas dependiendo del tipo de pared. / **FR ! Attention:** Utilisez toujours une fixation adaptée à votre type de mur. / **DE Achtung:** Bitte verwenden Sie für ihr Mauerwerk geeignetes Befestigungsmaterial. / **IT Attenzione:** I fissaggi devono essere scelti a seconda del tipo di muro. / **PL Uwaga:** Stosuj mocowania ścienne odpowiednie do rodzaju ściany. / **NL Waarschuwing:** gebruik altijd bevestigingsmaterialen die geschikt zijn voor uw wand-type. / **BG Внимание:** Винаги използвайте подходящи крепежни елементи, според вида на стената. / **RU Внимание:** Всегда используйте подходящий для Вашего типа стены крепеж. / **GR Προσοχή:** Για την καλύτερη εγκατάσταση προτείνουμε να χρησιμοποιείτε πάντα τα κατάλληλα στηρίγματα. / **CZ Pozor:** Použijte prosím takové montážní prvky, které odpovídají typu stěny. / **RO Atenție:** Elementele de fixare trebuie să fie alese în funcție de tipul de perete. / **LT Įspėjimas:** Visada naudokite tinkamus tvirtinimo elementus, atitinkančius jūsų sienos tipą. / **EE Ettevaatus:** Kasutage alati sobivaid kinnitusi, mis sobivad teie seinatüübiga. / **LV Uzmanību:** Vienmēr izmantojiet piemērotus stiprinājumus, kas atbilst jūsu sienas tipam. / **CRO Napomena:** Uvijek koristite odgovarajuće pričvršne elemente koji odgovaraju vašoj vrsti zida. / **RS Oprez:** Uvek koristite odgovarajuća pričvršćivanja koja odgovaraju vašem tipu zida. / **HU Figyelem:** Mindig a faltípusnak megfelelő rögzítést használjon. / **SLO Pozor:** Vedno uporabite ustrezne pritrdilne elemente glede na tip stene.

R4 x 8	P0 x 8	K1 x 4	H x 2				
A1 x 14	F8 ~ 20	E1 x 14	 Karta Gwarancyjna Warranty card Garantiekarte				
G x 4	W9B x 2	F1 x 14					
D1 x 4	N5 x 4	O1 x 4	 40 30 20 10 0				
			<table border="1"> <tr> <td>BZ0 x 4</td> <td>BZZ0 x 4</td> </tr> <tr> <td>M10 x 8</td> <td>WK10 x 8</td> </tr> </table>	BZ0 x 4	BZZ0 x 4	M10 x 8	WK10 x 8
BZ0 x 4	BZZ0 x 4						
M10 x 8	WK10 x 8						

4

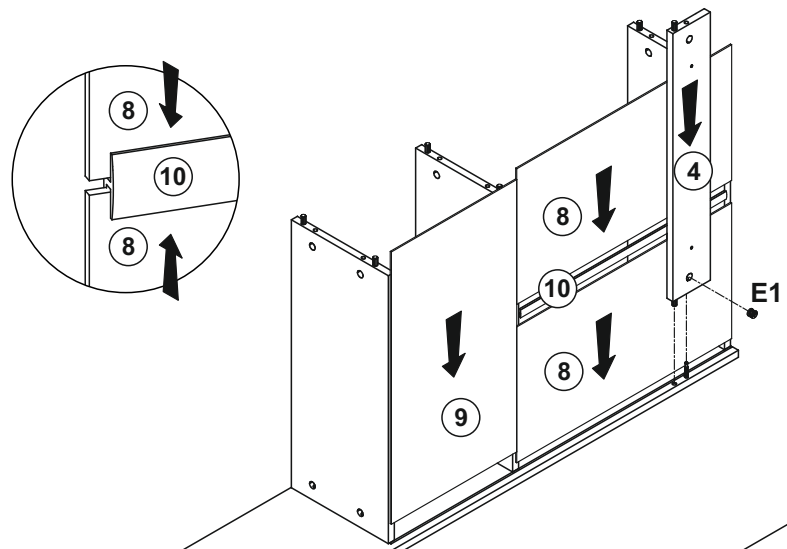

5

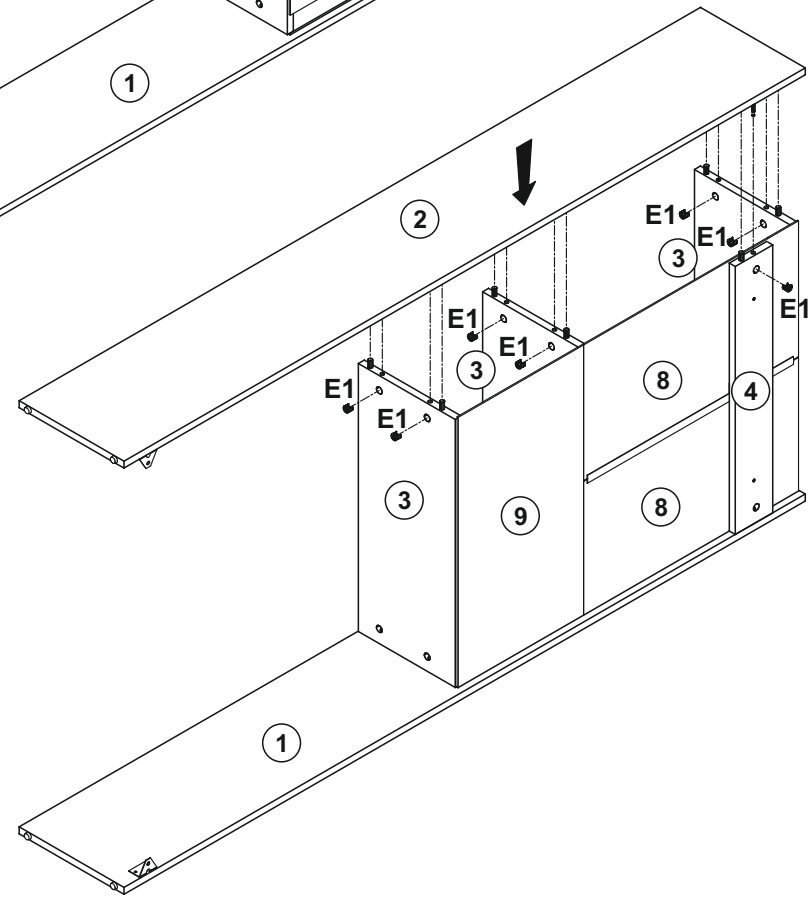

6

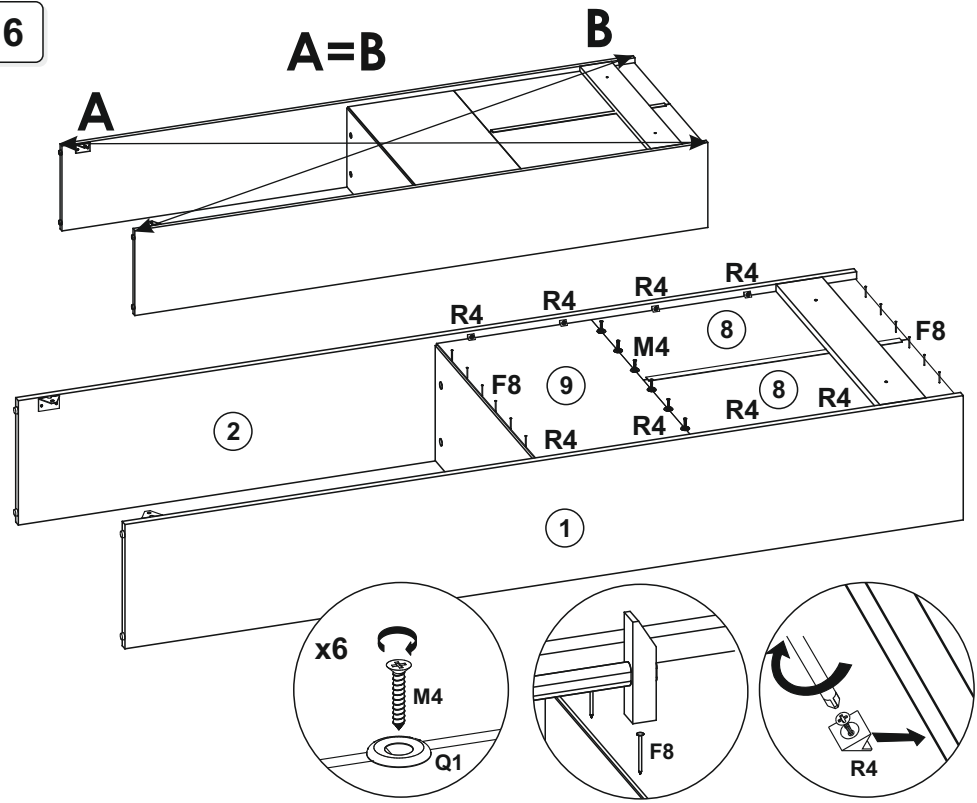

7

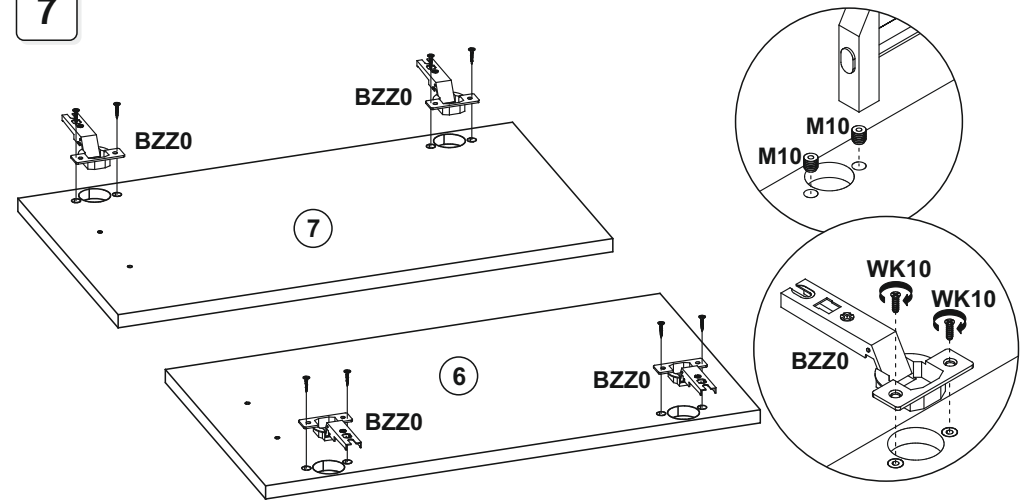

8

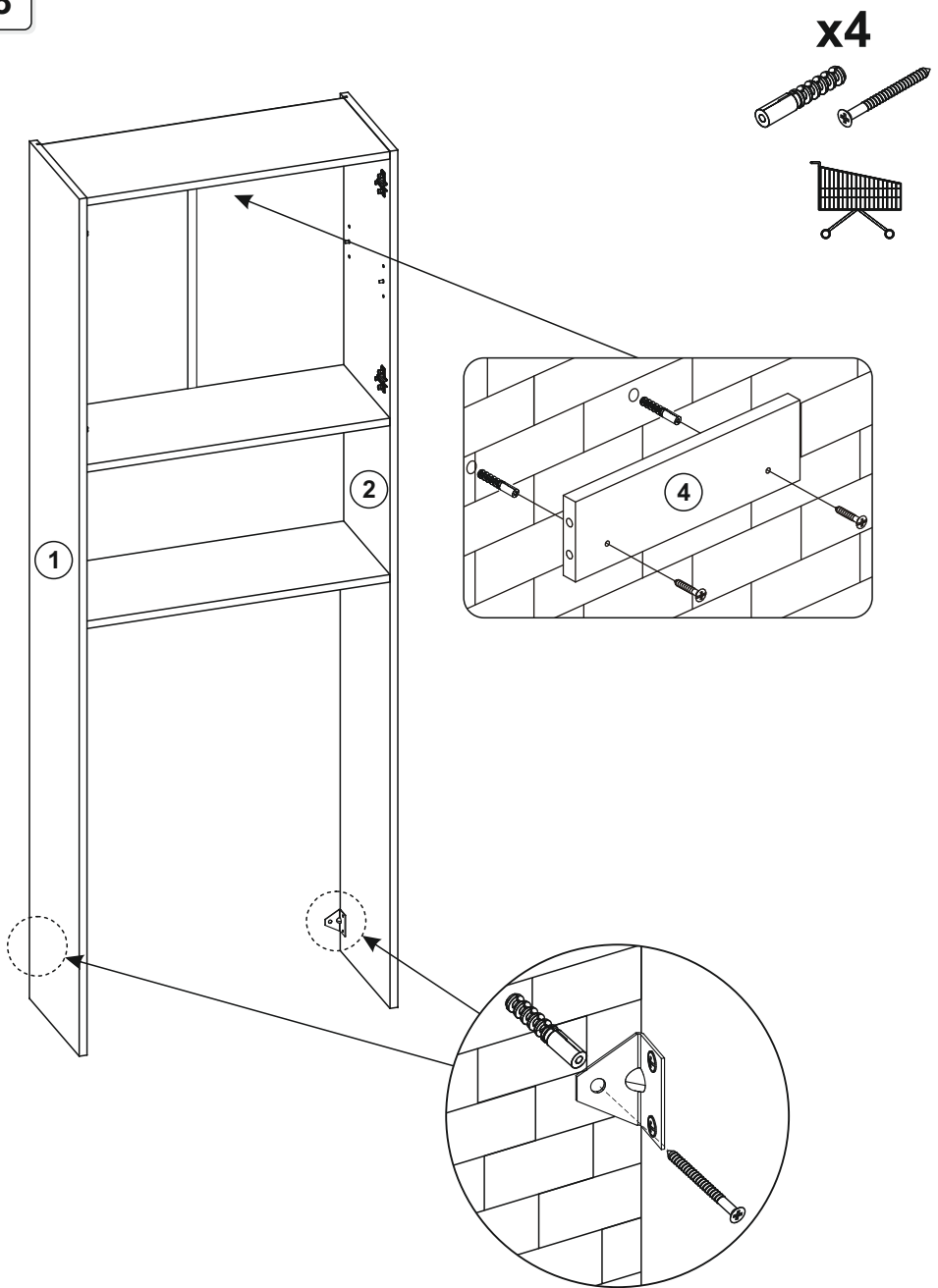

9

